

REVISIONS					
ZONE	REV	DESCRIPTION	DATE	DWN	CHK
-		RELEASED PER ECN P9603011			
A		REDRAWN & UPDATED IN AUTOCAD PER ECN 1006659	2-28-00	DJC	RNS

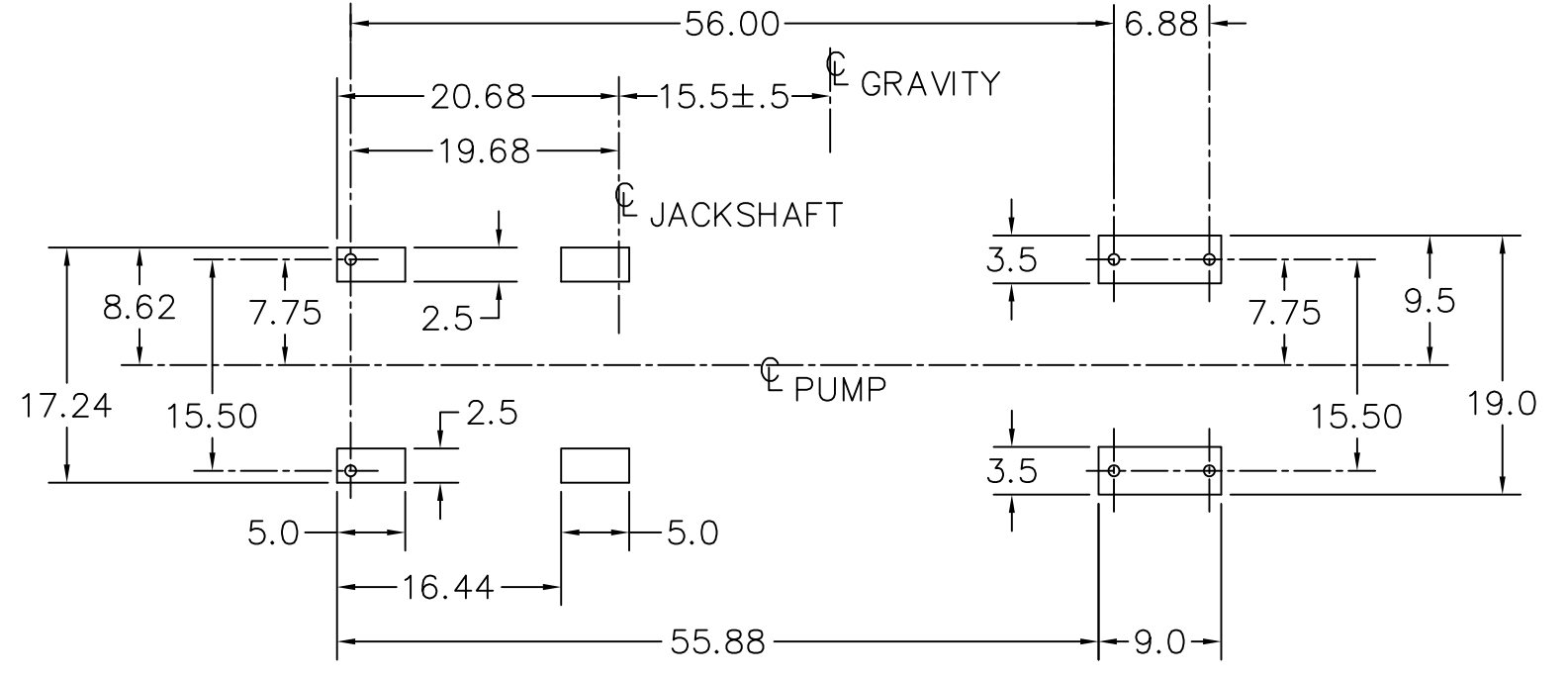

MOUNTING HOLES WITHOUT SKID

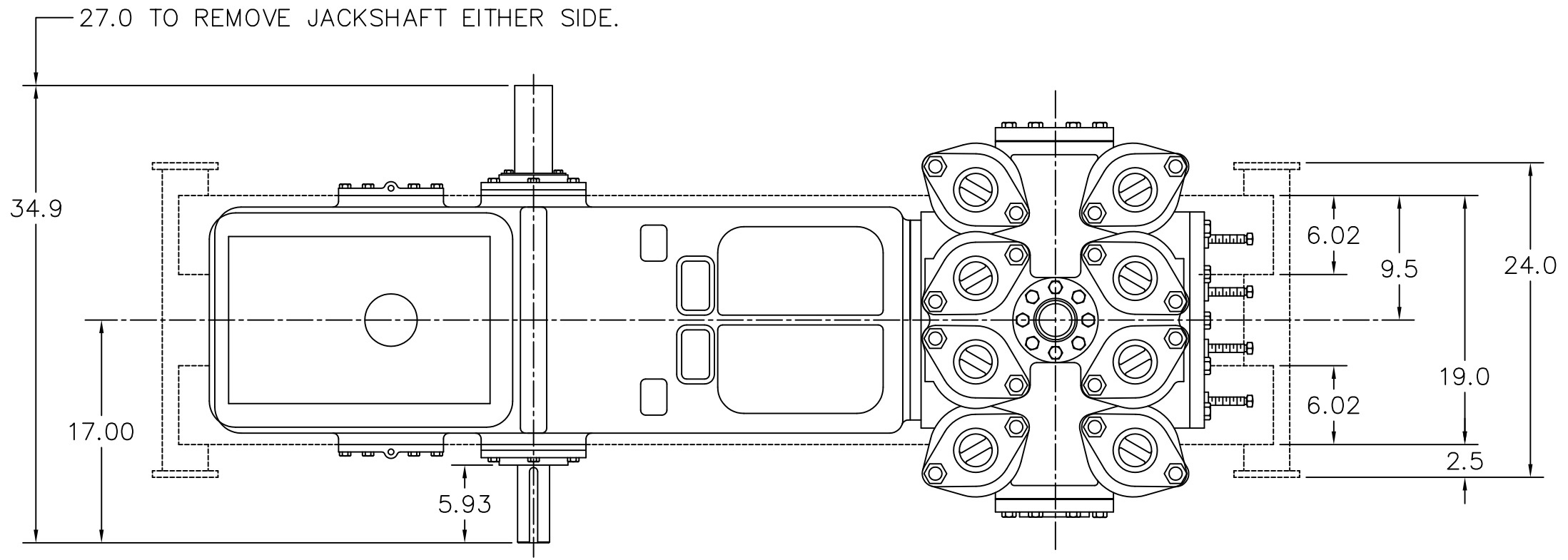
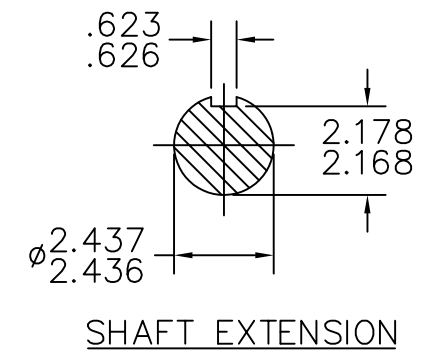
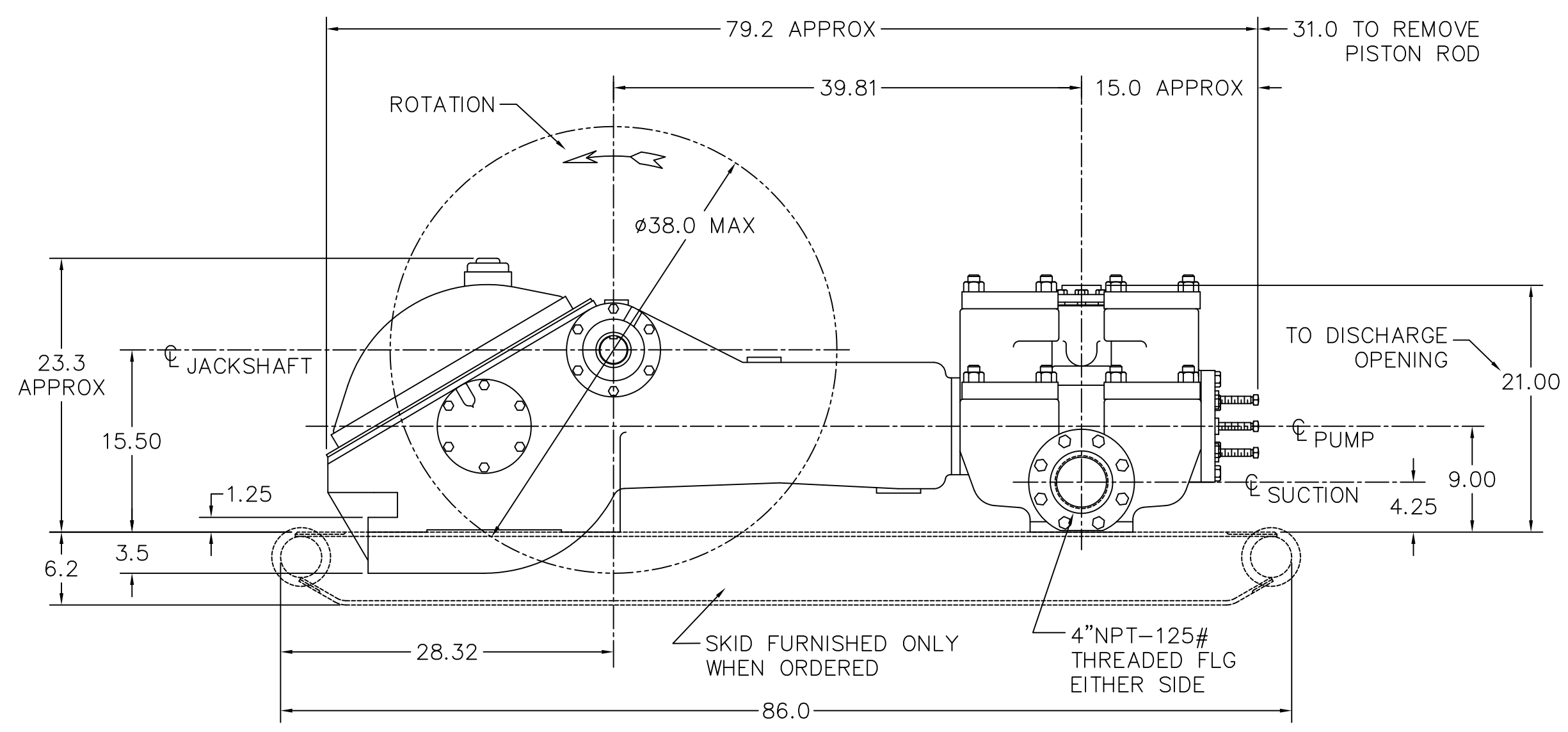

SHAFT EXTENSION

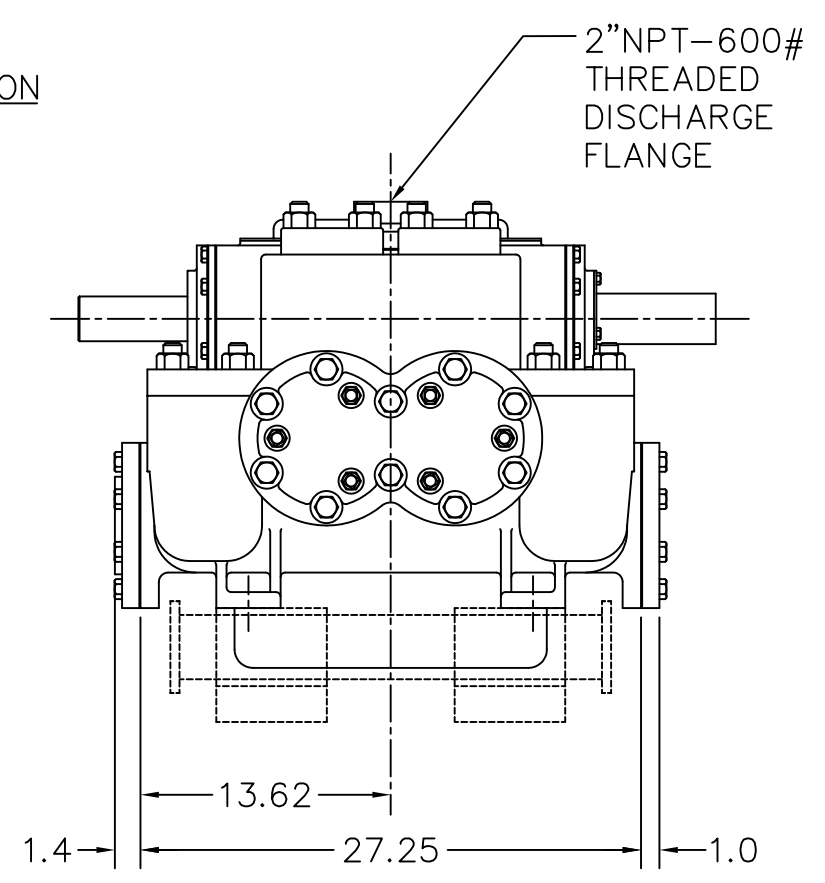

FINISH OF CHAMFERS & FILLETS TO CONFORM TO ROUGHEST ADJACENT AREA. SURFACE ROUGHNESS MAX. PER ASME B46.1 SPEC. TAP DRILL DEPTHS ARE MAXIMUM. FULL THD DEPTHS ARE MINIMUM.

UNLESS OTHERWISE SPECIFIED DIMENSIONS ARE IN INCHES
TOL. ON DECIMALS: .X = ±.05
TOL. ON DECIMALS: .XX = ±.02
TOL. ON DECIMALS: .XXX AS SPECIFIED
TOL. ON ANGLES: ± 0°-30'

THIRD ANGLE PROJECTION

CONFIDENTIAL - THE INFORMATION CONTAINED IN THIS DOCUMENT IS THE PROPERTY OF GARDNER DENVER, INC. IT IS NOT FOR PUBLIC DISCLOSURE. POSSESSION OF THE INFORMATION DOES NOT CONVEY ANY RIGHT TO LOAN, SELL, OR DISCLOSE THE INFORMATION. UNAUTHORIZED REPRODUCTION OR USE OF THE INFORMATION IS PROHIBITED. THIS DOCUMENT IS TO BE RETURNED TO GARDNER DENVER, INC. UPON THE COMPLETION OF THE PURPOSE FOR WHICH IT IS LOANED OR UPON REQUEST.

DIMENSIONING AND TOLERANCING PER ASME Y14.5M-1994

Gardner Denver

HEAT TREATMENT ENG. REF:

TITLE: **OUTLINE-BARE UNIT
FXGA THRU FXGE**

Gardner Denver Inc.
Quincy, IL.

DWN BY: DJC 3-3-96 SIZE: E ENGINEERING APPROVAL: DWG NO.: 300FXG800 REV: B

CK'D BY: VS 3-3-96 SCALE: 1/6 SHEET: 1 of 1